

# SUGARPLEX

SUGAR SWEETENS UP YOUR LIFE



# HOSOKAWA ALPINE

PROCESS TECHNOLOGIES FOR TOMORROW<sup>SM</sup>



## THROUGHPUT 315 SX

| Fineness values                 | Throughput |
|---------------------------------|------------|
| 99 % < 125 µm (120 mesh)        | 1,000 kg/h |
| 99 % < 150 µm (100 mesh)        | 1,500 kg/h |
| 99 % < 212 µm (70 mesh)         | 2,000 kg/h |
| 99 % < 315 µm (approx. 45 mesh) | 2,500 kg/h |
| 99 % < 450 µm (approx. 35 mesh) | 2,800 kg/h |

## IMPORTANT FACTS

- Space-saving design
- System height < 2,500 mm (including rotary valves)
- Low capital investment
- Low energy consumption
- Airless concept
- No filter necessary
- No air conditioning necessary
- No cooling necessary
- ATEX-compliant, pressure-shock-proof to 10 bar (g)
- GMP-compliant
- Optional: additive dosing (e.g. for starch)

## SUGARPLEX APPLICATIONS

The design of the Sugarplex pin mill is based on the proven grinding principle of the Alpine UPZ fine impact mill, and is tailored to the specific requirements of the sugar industry. The mill produces finely ground sugar for:

- Instant beverages (e.g.: tea, cappuccino)
- Confectionery (e.g.: muesli bars, ice cream, chocolate, pralines, biscuits)

The mill is also ideal for grinding products with the following properties:

- Products with a high flow rate
- Potentially explosive products
- Temperature range 30-60°C

We will be happy to run trials in our application testing centre with your product.

This extremely compact system needs neither additional filters nor fan nor cooling equipment which is the standard with conventional system concepts for grinding sugar. This means that system users profit from the lower investment costs, a more modest space requirement and lower cleaning and maintenance costs. The cylindrical design of the mill is comprised by the round bin with conical product discharge and is perfect for integration into an existing system.

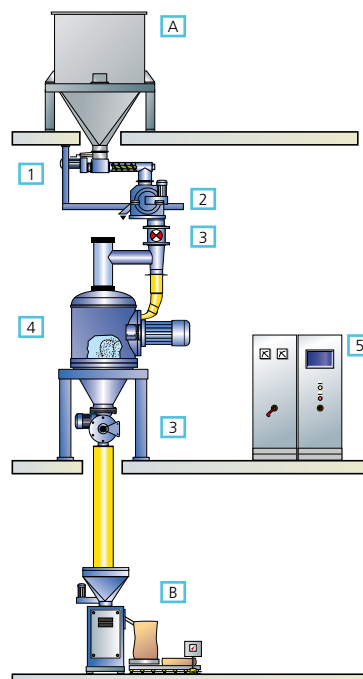

- 1 Feed metering screw
- 2 Metal separator
- 3 Rotary valve
- 4 Sugarplex SX
- 5 Process control
- A Product feed
- B End product



## PRINCIPLE OF OPERATION

The coarse sugar is fed by a rotary valve through the mill door to the centre of the grinding zone. The grinding unit, comprising two pin discs, is integrated into the mill door. The door can be opened quickly, easily and opens wide, meaning that the user can inspect or clean the grinding elements at any time.

A special seal ensures that neither lubricant can ingress the product zone nor can sugar or rinsing water get into the motor. A frequency converter is used to steplessly adjust the speed of the motor and to set the required fineness.

Because the Sugarplex was developed especially for the food industry, it fulfils all fundamental safety and health regulations included in the EU Machinery Directive 98/37 EC Annex II A as well as all safety and accident prevention regulations currently prevailing in Germany. The concept and design of the mill conform with all relevant harmonised EC standards (e.g. EC 1935/2004), as well as the applicable national DIN standards. The Sugarplex is ATEX-compliant and suitable for operation in Zone 20 (inside) and Zone 22 (outside).

➤ **SUGARPLEX:**  
*THE SWEETEST EVOLUTION  
IN THE GRINDING BUSINESS  
WORLDWIDE*

## MACHINE SIZES

| Sugarplex   | Scale-up factor (F) | Mill drive (kW) |
|-------------|---------------------|-----------------|
| 250 SX      | 0.5                 | 11              |
| 315 SX      | 1                   | 18              |
| 315 SX Twin | 2                   | 2 x 18          |
| 500 SX      | 2                   | 37              |
| 630 SX      | 3.6                 | 75              |



➤ *Sugarplex 315 SX Twin*

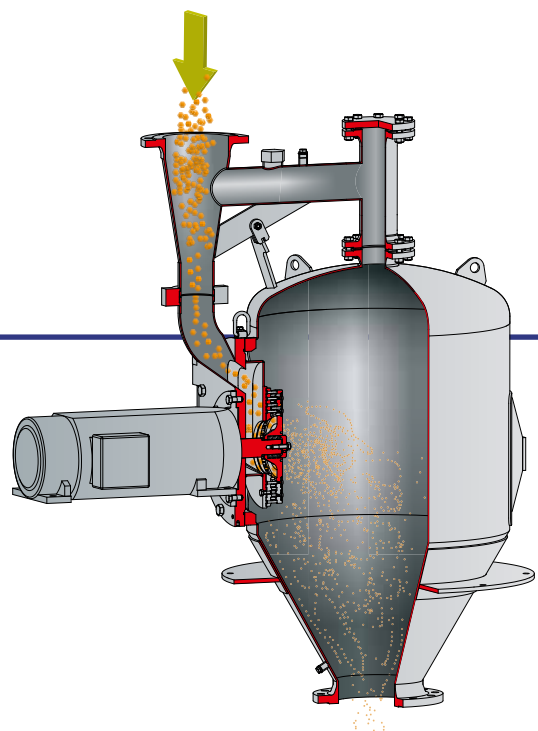

HOSOKAWA ALPINE Aktiengesellschaft

P. O. Box 10 11 51

86001 Augsburg

GERMANY

Address for visitors and deliveries:

Peter-Doerfler-Straße 13–25

86199 Augsburg

GERMANY

Tel: + 49 821 5906-654

Fax: + 49 821 5906-655

E-mail: [food@alpine.hosokawa.com](mailto:food@alpine.hosokawa.com)

[www.hosokawa-alpine.com](http://www.hosokawa-alpine.com)

Subject to change without notice.  
All information in this brochure is purely  
informative and non-binding.  
Our quotations are authoritative  
with regard to orders.



## **HOSOKAWA ALPINE Aktiengesellschaft**

Hosokawa Alpine is a member of the Hosokawa Micron Group, a high-performance manufacturer of systems for powder and particle processing, systems for the confectionery industry as well as plastics processing machines and systems. The Hosokawa Micron Group is known and reputed the world over for its power of innovation, constant product care and market-oriented R&D. The most important group resources are R&D, engineering and manufacturing as well as customer service in all global markets.

© Hosokawa Alpine 2014. Printed in Germany.