

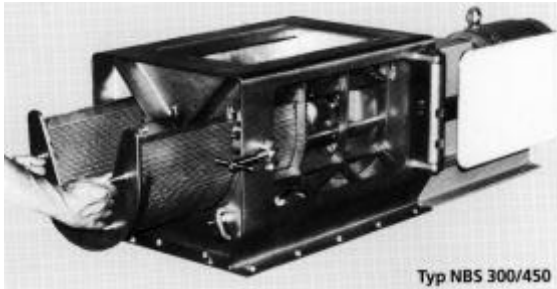

Nibbler

Delumper / Deagglomerator in a compact and robust design



- Suitable for disintegrating relatively soft lumps such as lumps hardened during storage in hoppers or silos agglomerates formed through drying or wet-filtering processes.
- Product size control can be available in range of around 30meshes to a few millimeters by change of screen.
- Easy and quick screen changes offers easy cleaning and servicing.
- By screen itself material is also being disintegrated.
- Rotor speed is extremely low so fine dust and noise generation kept minimum.

Construction

The Nibbler will shred and cut the feed material between the slowly moving rotor and screen. After disintegrated, materials passed through screen are discharged as products. On this rotor beaters as shown in Fig. 1 are fixed. Beaters are movable so the clearance between the screen can be adjusted. Screen itself has something like corrugated shape as shown in Fig. 2, enabling effective disintegration on its inner surface. Product control is made by change of opening size of screen.

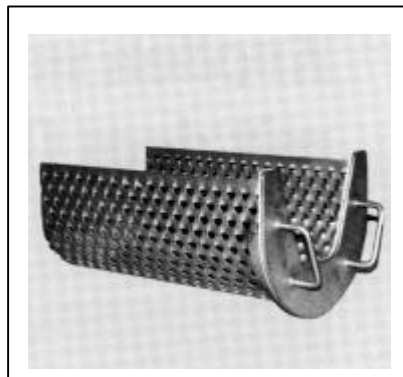

Fig.2

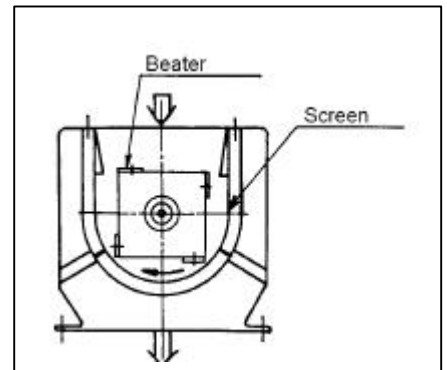

Fig.1

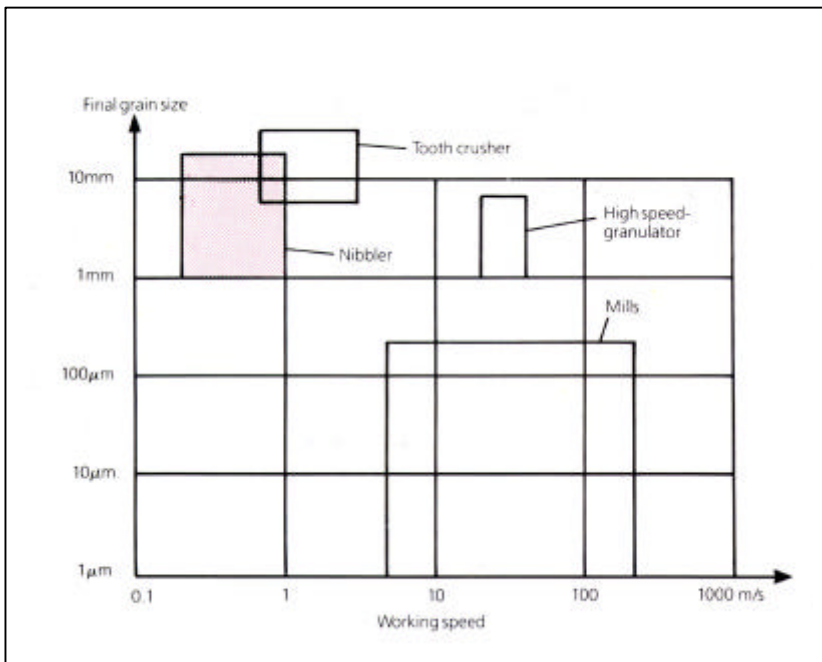

Fig. 3

Advantages

1. Minimum fine dust generation.
2. Easy adjustment of product size.
3. Easy Maintenance and cleaning inside.
4. Low energy consumption

The Nibbler has a low working speed in comparison with other size reducing machines. the resulting benefits are;

- Less tendency to produce undesirable fines.
- Low energy consumption
- Rotational speed of less than 1m/s makes the Nibbler applicable for use with explosion risk products.



Specifications

Model : NBS-300/450
 Material : Carbon Steel or stainless steel 304
 Required power : 3.7 kW geared motor
 Rotor speed 75 / 90 rpm (50/60Hz)
 Available screen size: 2,3,4,6,8,11mm
 Feed inlet size : 300 x 450mm
 Weight : 350kgs

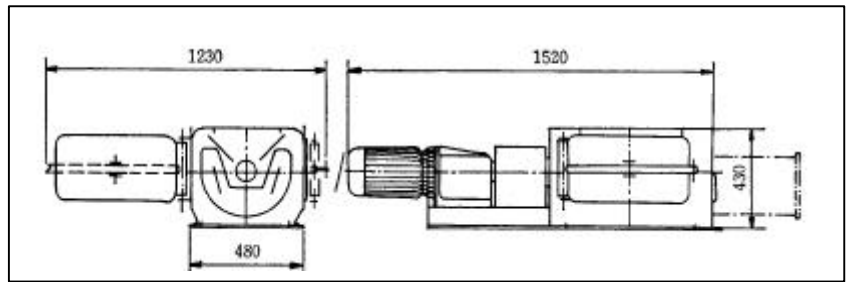

Fig.4

Application

Nibbler is suitable for the use in pre-processing to pneumatic conveying, fine grinding, mixing, solving and packing. Nibbler is very effective if used as pre-processing, to obtain optimum performance of those processes. Some installation examples are shown in Fig. 5 and table. 1

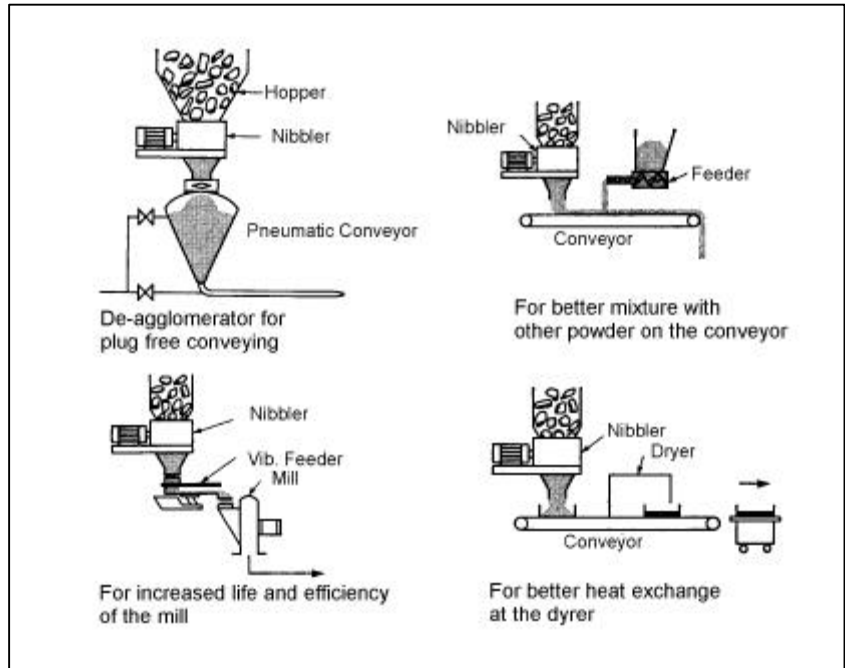

Fig.5

Application Examples

Material Name	Motor Power	Capacity kg/hr	Feed Size	Product Size
Pharma intermediate	3.7	- 2,000	max. 30x30x100mm	0.5mm
Urea organic material	3.7	1,500	50x30x20mm	5-6mm
Microcrystalline Cellulose	3.7	600	300x300x20mm	around 18mm
Chroline Agglomerates	3.7	3,000	powder contains some lumps	delumping
Aggrochemicals	3.7	1,000	10-20cm	below 1mm
Detergent	3.7	1,500	agglomerates 10mm	4-6mm
Phenolic Resin	3.7	170	Plate 50 x 200mm	D50 15x15mm
Activated Carbon	3.7	2,500	50mm	below 2-3mm
Adipic Acid	3.7	15,000	max. 300mm	D50 10mm

Table 1



HOSOKAWA MICRON CORPORATION

Hosokawa Micron Corporation is a member of the Hosokawa Micron Group, responding to global needs through emphasis on materials equipment and systems for powder processing, thermal processing, and plastics processing. The Group maintains facilities for research, engineering, manufacturing, and service in each of the world's industrial markets.

Hosokawa Group Asian Network

- Hosokawa Micron Corporation
5-14, 2-Chome, Kawaramachi, Chuo-Ku, Osaka, Japan
Phone:81-6-6233-3968, Fax:81-6-6229-9267
- Hosokawa Micron (Korea) Ltd.
Phone : 82-2-420-5691, Fax : 82-2-420-5693
- Hosokawa Micron Corporation, Shanghai Rep. Office
Phone : 86-21-5306-8031, Fax : 86-21-3218-1387
- Hosokawa Micron (Malaysia) Sdn. Bhd.
Phone : 60-3-5636-5063, Fax : 60-3-5634-3946
- Hosokawa Micron Thai Rep. Office
Phone :66-2-312-5300, Fax: 66-2-312-5301