

BATCH & CONTINUOUS MIXING



HOSOKAWA MICRON B.V.

PROCESS TECHNOLOGIES FOR TOMORROWSM

PROCESS FOR TECHNOLOGIES TOMORROW

ABOUT HOSOKAWA MICRON B.V.

Hosokawa Micron B.V. is specialist in the design, manufacture and supply of powder processing systems and equipment for the mechanical and thermal processing of dry and wet powders. Located in Doetinchem in The Netherlands, Hosokawa Micron B.V. is expert in mixing, drying and agglomeration.

Hosokawa Micron B.V. was established in 1987 as a result of a merger between Nautamix in Haarlem (founded in 1923), Machinefabriek Vrieco in Zelhem (founded in 1939) and ISEM in Doetinchem (founded in 1928). In 2000 Schugi in Lelystad (founded in 1954) was merged into the company. Today, Hosokawa Micron B.V is one of the main companies within the Hosokawa Group.

MISSION STATEMENT

Hosokawa Micron B.V. is a leader in offering technological know-how and solutions in the field of mixing, drying and agglomeration. By our professionalism, service orientation and dedication we help clients to achieve their goals, or even exceed them. In doing so we achieve long-term relationships with both clients and suppliers as well as an attractive return for our shareholders.

We offer a challenging and motivating work environment for our employees and want to contribute to a sustainable society.

CONTENTS

| | |
|----------------------------|----|
| ABOUT HOSOKAWA MICRON B.V. | 2 |
| MIXING TECHNOLOGIES | 4 |
| MIXER SELECTION | 6 |
| BATCH MIXING | 8 |
| CONTINUOUS MIXING | 18 |
| LAB EQUIPMENT | 24 |
| ANCILLARIES / OPTIONS | 25 |
| SYSTEM SOLUTIONS | 26 |
| PROCESS AUTOMATION | 28 |
| SERVICE & SUPPORT | 30 |
| TESTING & TOLLING | 32 |
| INDUSTRIES | |
| FOOD INDUSTRY | 34 |
| PHARMACEUTICAL INDUSTRY | 36 |
| CHEMICAL INDUSTRY | 38 |
| MINERALS & METALS INDUSTRY | 40 |
| CONTACT | 42 |



Mixing
Drying
Agglomeration

Food
Pharmaceuticals
Chemicals
Minerals & metals

MIXING TECHNOLOGIES

SELECTING THE RIGHT MIXER

The first step to selecting the right equipment is a thorough analysis of the powders (and liquids) you wish to process. This analysis will give you a clear understanding of all of the medium's characteristics, which need to be taken into account during processing.

Some powders need a gentle mixing, while others need more mixing energy to create a quality mixture. Design parameters, for example, cross contamination between batches and operating pressures will also influence the final design of the mixer.

In this brochure, we have divided the mixers according to their suitability for batch and continuous applications, ranging from low shear (gentle mixing) to high shear (intensive mixing).

Hosokawa Micron B.V. is certified according to the international standard NEN-EN-ISO 3834-2 for welding. The ISO 3834 quality standard applies to all activities in the field of welding and covers the entire welding organisation.

State-of-the-art powder processing solutions

Hosokawa Micron B.V. specialises in the design and manufacture of innovative technologies for powder processing in a number of industries, including food, pharma, chemicals and minerals & metals. By focusing on these over the years, we have developed in-depth and unparalleled experience and know-how that we enjoy sharing with our customers.

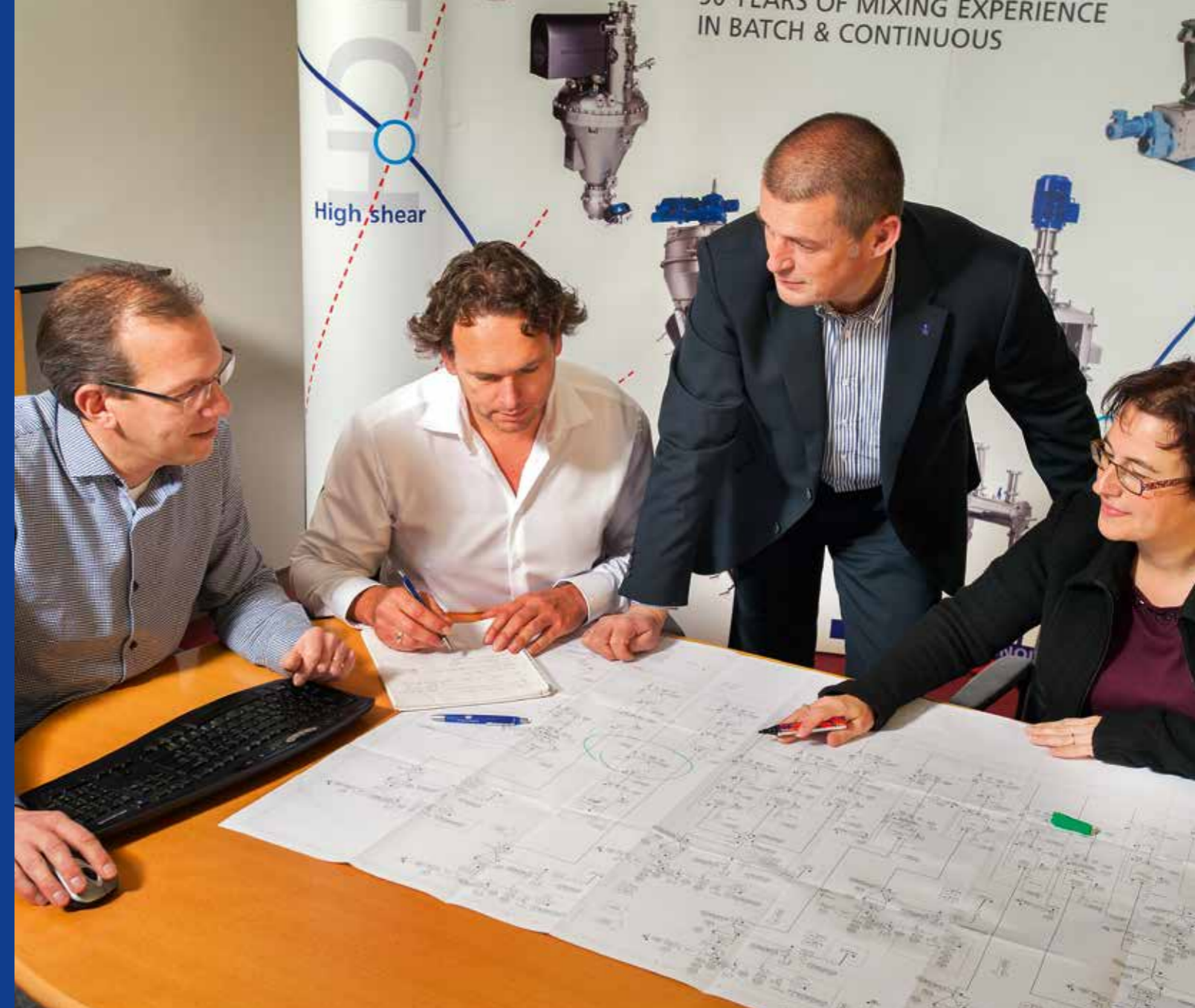

CHALLENGE US TO SOLVE YOUR MIXING PROBLEMS!

MIXING TECHNOLOGIES AT HOSOKAWA MICRON

Mixing is one of the oldest unit operations in powder processing and we have dedicated over 90 years to developing experience and know-how in this field. We have translated this wealth of knowledge into different technologies such as the Nautamix, Vitomix, Cyclomix and Flexomix, which are now strong brands and fundamental technologies in a great number of industries and applications.

Hosokawa Micron provides a powerful combination of complete powder processing solutions. These encompass innovatively-designed and expertly-engineered mixing, drying, agglomeration, milling and containment technologies, as well as ancillary equipment, assembly, commissioning, on-site training and process optimisation.

Our R&D centre in Doetinchem, The Netherlands, provides valuable test facilities for customers looking to perform mixing tests on a laboratory, pilot and production scale. These are unique and enable us to offer the perfect mix of technology and powder processing knowledge all under one roof.



Agrochemicals
Flavours **Food ingredients**
Polymers Metal powders
Ceramics **Bulk pharmaceuticals**
Injectables Mineral fillers
Pigments **Catalysts**

Mixer selection

BATCH

High shear/impact mixer

The Cyclomix is a high shear intensive mixer specially designed for fine cohesive powders, slurries and liquids.



Ribbon screw mixer

The Vitomix is a low and mid-shear mixer, capable of ultra-quick cycle times, with up to 8 times more transport volume than conventional screw cone mixers.



High shear

Mid shear

Low shear

Conical paddle mixer

The conical paddle mixer is a low and mid-shear mixer for mixing powders, granules and solids with liquids. It is a multi-purpose mixer for processes where high accuracy, speed and limited product distortion are important.



Conical screw mixer

The Vrieco-Nauta conical screw mixer is a low intensity mixer specially designed for segregative, free-flowing materials and pastes. The Vrieco-Nauta is also suitable for cohesive products when used in combination with an intensifier.



CONTINUOUS

High speed paddle mixer

The Bepex Turbulizer is a high speed continuous paddle mixer developed for fine and cohesive powder applications. The mixing intensity can be tailored to the specific application by adjusting paddle pitch and shaft speed.



High impact mixer

The Schugi Flexomix is a high intensity continuous mixer, developed to perfect the mixing of free-flowing and cohesive powders with liquids.



High shear

Modular mixer

The Modulomix is a continuous modular mixer based on the proven Cyclomix batch mixing technology. It can be used for low, medium or high shear applications and it can be integrated into a PAT (Process Analytical Technology) environment.



Mid shear

Conical screw mixer

The Vrieco-Nauta mixer is a conical screw mixer specially designed for segregative, free-flowing powders and pastes. It is a pioneer in mixing technology and famous for its low-intensity mixing. The Vrieco-Nauta mixer is a direct descendent of the first conical Nauta mixer, which was developed by Mr. J.E. Nauta in 1946. In 1982 the Nautamix company was acquired by Hosokawa Micron.

Today, the Vrieco-Nauta batch mixer is synonymous worldwide with high accuracy and gentle mixing of large volumes of up to 100 000 litres. As the innovators, Hosokawa Micron B.V. continue to dedicate research and development into this leading mixing technology and sold more than 15 000 conical mixers in a wide variety of applications.

Typical applications

Vrieco-Nauta mixers are suitable for a wide range of processes and applications:

- Gentle mixing of free flowing, fragile and/or segregative powders
- Mixing of pastes and slurries
- Liquid addition to powders and pastes
- Temperature treatment, cooling/heating
- Reactor vessel in pressurised conditions/vacuums
- Live hopper for sticky or segregative products

Working principle

The Vrieco-Nauta conical screw mixer is a convective mixer with high mixing efficiency. It is gentle and guarantees the highest level of mixing accuracy without product distortion. The screw has an average speed of 70 rpm whilst the arm rotates at 1 to 2 rpm. The tip speed of the screw can fluctuate between 0.5 and 2 m/s, making it suitable for all ATEX zones.

The rotating cantilevered mixing screw conveys the product from the bottom of the vessel to the product surface. The mixing screw is suspended from an orbital arm, which rotates the mixing screw along the conical inner vessel wall causing convective mixing of particles and shear.

When recirculated by gravity in a conical vessel, the speed of particles in the downward mass flow increases as the vessel diameter decreases. These simultaneous actions result in fast and intensive mixing with low power consumption and high mixing accuracy.

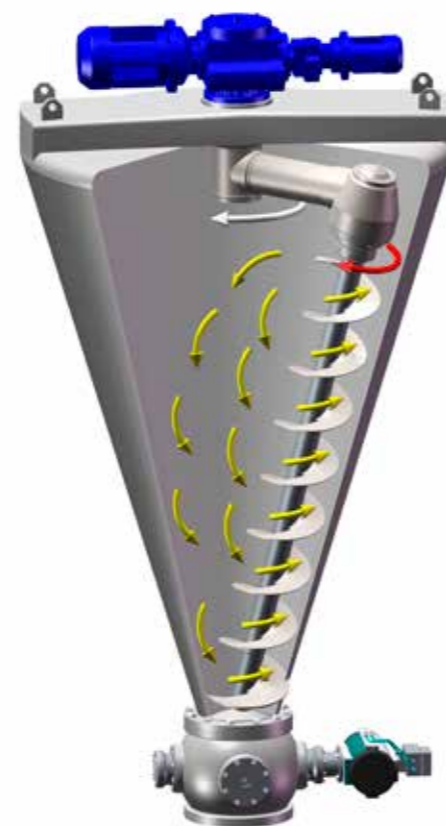

Batch mixing



Mixer configuration

The Vrieco-Nauta mixer is available in a wide variety of configurations for a broad range of process and application requirements. We have included some of the most common configurations below.

Vessel/cover design



Flat cover

- For normal atmospheric conditions
- No special cleaning requirements
- Bolted to mixer vessel

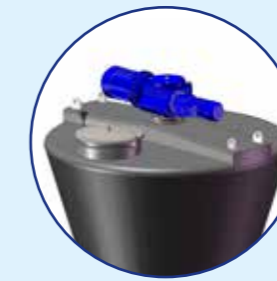

Semi-domed cover

- Up to 0.1 bar positive/negative pressure
- Suitable for dry and wet cleaning
- Integrated with vessel and support bridge



Domed cover

- Full vacuum and up to 10 bar
- Sanitary design
- Integrated with vessel

Mixing elements



Single screw configuration

- Standard execution
- Variety of designs

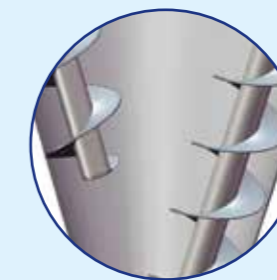

Double screw configuration

- Reduced mixing times
- Improved heat transfer

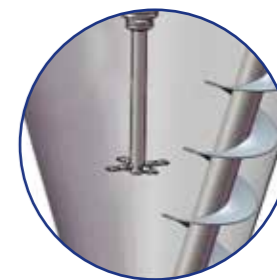

Intensifier

- Provides additional mixing energy
- Can be combined with liquid spray devices

Screw support



Cantilevered (no support)

- Suitable for mixers up to 20 000 litres
- For heat sensitive and fragile products
- Full discharge / bottom outlet
- For sanitary applications and easy cleaning

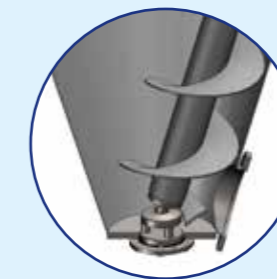

Radial bottom locator

- Suitable for mixers up to 12 000 litres
- For heavy duty applications
- In combination with side outlet



Ball head bearing

- Suitable for mixers up to 100 000 litres
- Heavy-duty and heat-sensitive applications
- In combination with side outlet

Batch mixing

Heating/cooling

A jacketed vessel can be supplied to heat or cool the product. Dependant on temperature, pressure and medium, one or several jacket segments are welded to the vessel wall fully in compliance with the requirements of coding authorities. The jacket is designed to force the medium around the vessel achieving maximum temperature transfer effect.



Cleanability

When it comes to cleaning mixing equipment, we ask ourselves what the best way is of combining our smart designs with your quality manufacturing processes. Minimising downtime is the ultimate goal, but it would be naïve to think we could avoid time-consuming cleaning processes for mixing operations all together.

The determining factor when choosing a particular type of cleaning is your application. There are many aspects to consider, and plenty of philosophies about cleaning, but one of the most difficult questions to answer is when something is truly clean, and how to control the results.

To this end, we offer three categories of cleaning:

- Wet cleaning
- Dry cleaning
- Sterilisation

We offer a range of fixed or removable cleaning systems for automatic (wet) cleaning using gas and liquid cleaners. These include customised CIP and drying skids. We also have large access doors, platforms and manual spray lances for (wet) cleaning your systems manually, ensuring good and safe accessibility to the areas that need to be cleaned.

This is an integral part of the design phase and our specialists are here to help you incorporate this into your mixer design right from the start. Our expert advice on cleanability in combination with sustainability will help you save costs, protect the environment and achieve the best possible results.



Key features

Proven technology

Hosokawa offers you their experience of 15 000 successful references since the development of the first conical Nauta-mixer in 1946. Since then, numerous improvements have been made. Thanks to our continuous dedication to product development, the Vrieco-Nauta mixer is acknowledged globally as a state-of-the-art mixing technology for the powder processing industry.

Perfect quality

It can be used for low intensity with a minimum of energy input, and produces minimal product distortion, perfect quality and accuracy for a wide range of powders, slurries and liquids. The Vrieco-Nauta mixer is very flexible and delivers constant mixing quality with mixer volumes of 15% all the way up to 100%.

Versatile

The Vrieco-Nauta mixer can be configured to suit applications in the chemical, mineral, metal, food, pharmaceutical and nuclear industries. It can be designed to provide effective heating, cooling, drying, mixing and moistening in one complete process and can be adapted for use in hazardous areas (ATEX approved).



World renowned
Gentle mixing **Proven technology**
Versatile **Efficient**
Accurate **Flexible**

Models & specifications

The Vrieco-Nauta mixer is available in more than 50 sizes, ranging from 3.3 up to 100 000 litres. A few sizes with their basic characteristics are described below. Detailed information is available on request.

| Size | [l] | 500 | 1000 | 2000 | 5000 | 10 000 | 20 000 | 50 000 | 100 000 |
|---------------------|------|------|------|------|------|--------|--------|--------|---------|
| Vessel diameter | [mm] | 1450 | 1800 | 2100 | 2850 | 3550 | 4400 | 5700 | 7000 |
| Vessel height | [mm] | 1750 | 2250 | 2800 | 3800 | 5000 | 6000 | 8250 | 9000 |
| Height incl. motor | [mm] | 2250 | 2900 | 3500 | 4700 | 6200 | 7300 | 9650 | 10 300 |
| Typical motor power | [kW] | 2.2 | 5.5 | 7.5 | 15 | 22 | 37 | 55 | 90 |

Conical paddle mixer

The conical paddle mixer is the newest generation of Hosokawa powder mixers, developed for low and medium shear batch mixing. It has been designed for mixing powders, granules and solids with liquids. The conical paddle mixer is a multi-purpose mixer for processes where high accuracy and fast mixing with limited product distortion are important.

Typical applications

The conical paddle mixer is suitable for a wide variety of process applications, including:

- Mixing of fragile powders and 'instant' agglomerates
- Mixing of powders with liquids
- Sterilisation and pasteurisation of product batches
- Temperature processing of powders and liquids
- (Vacuum) drying at low temperature with liquid recovery

Working principle

The mixing vessel is conical shaped and equipped with a central paddle rotor. When it rotates, the rotor creates a combination of vertical and axial motion in the vessel. The paddles guide the product gently to the surface of the batch, where it is dispersed and the gravitational pull at the centre of the mixer forces the product back down to create continuous motion throughout the mixing cycle, even at low speed.

The mixing process can be optimised by controlling the mixing energy, which can be achieved by adjusting the rotational speed. The conical paddle mixer has a typical rotor speed of between 1 and 10 m/s.

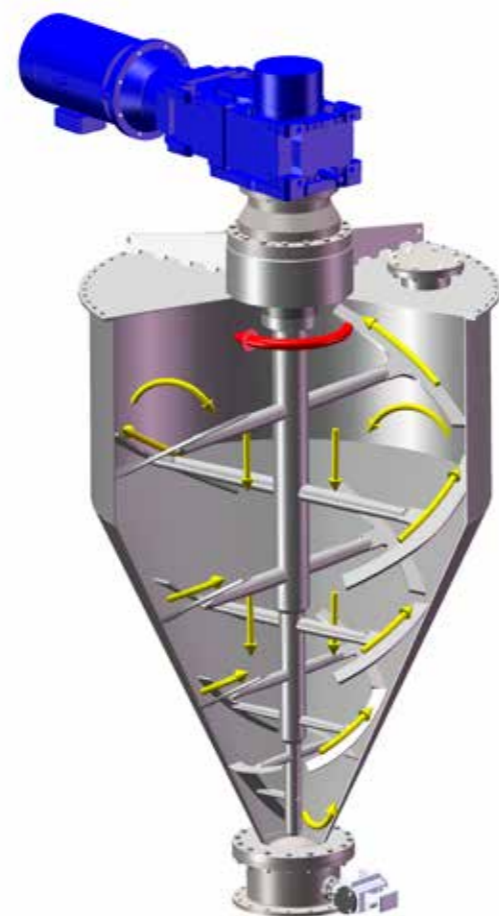

Batch mixing



Key features

Design

The heavy duty and smart design, with central rotor and external drive, makes the conical paddle mixer suitable for multiple processes. These can vary from high accuracy to heavy duty mixing, chemical reactions, and vacuum drying, to mixing processes which demand cleaning/sterilisation. Its compact design with conical shaped vessel and large bottom outlet, guarantee fast and full discharge. The typical yield for free-flowing powders is 99.99%.

Fragile products

The gentle mixing action combined with short mixing times, makes the conical paddle mixer suitable for fragile products with minimum product distortion.

Temperature control

The action of the mixing rotor keeps the product in constant motion, and in frequent contact with the vessel wall. This optimises the heat transfer between vessel and product, making the conical paddle mixer an ideal mixer for processes where temperature control and energy efficiency are key.



Multi processing Low & mid shear Heavy duty Temperature control

Models & specifications

The conical paddle mixer is available in several sizes, ranging from 1 up to 6000 litres. A few sizes with their basic characteristics are described below. Detailed information is available on request.

| Size | [l] | 5 | 50 | 500 | 1000 | 2000 | 3000 | 6000 |
|-------------------------|------|---------|-------|--------|---------|---------|------------|------|
| Vessel diameter | [mm] | 300 | 650 | 1400 | 1840 | 2250 | On request | |
| Outlet diameter | [mm] | 80 | 150 | 300 | 350 | 400 | | |
| Height incl. drive-unit | [mm] | 280 | 713 | 1178 | 2657 | 3125 | | |
| Typical motor power | [kW] | 0.5 - 1 | 1 - 4 | 4 - 20 | 10 - 40 | 30 - 80 | | |

Ribbon screw mixer

The Vitomix ribbon screw mixer is a multi-functional mixer that combines gentle and mid shear mixing in one machine. Compared to conventional conical mixers, the Vitomix has a compact design and a wide operating range. With up to eight times more transport volume, it is a very energy-efficient mixer with low operational costs and short mixing times.

Typical applications

The Vitomix is suitable for a wide variety of process applications, including:

- Fast mixing of powders, pastes and slurries
- Addition of liquids or fats without the use of lump breakers
- Combining gentle mixing with mid shear mixing in one machine
- Granulating
- Flavouring
- Colouring
- Heating / cooling

Working principle

The Vitomix is equipped with two conical ribbon screws mounted on an orbital arm that transports the product from the bottom of the vessel to the surface. The material flows downwards through the centre of the vessel by gravity whilst the high rotational speed of the agitator ensures mid-shear mixing in very short batch times.

The design of the two ribbon screws enables the transportation of large quantities of product to the surface of the batch where it is fluidised with a high degree of product refreshment. This technique makes the Vitomix ideal when you want to add liquids to the powder(s) you are mixing. The Vitomix has a variable tip speed of between 0.4 and 6 m/s.

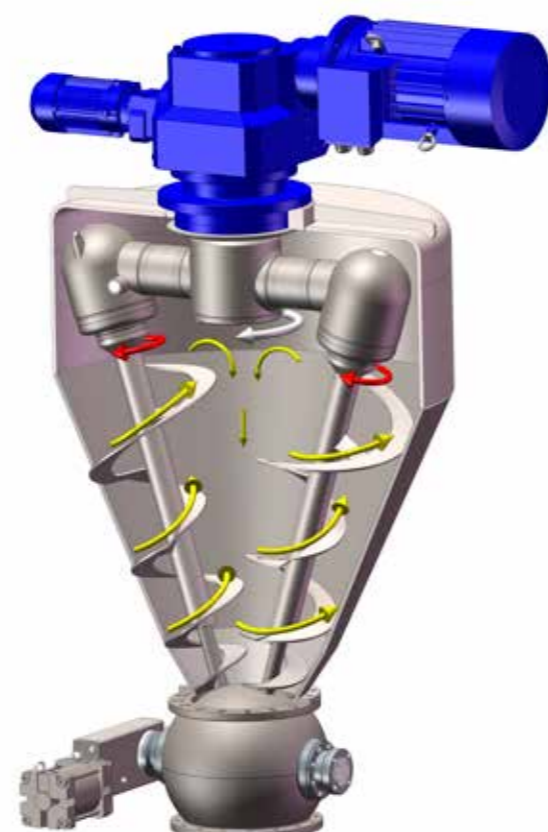

Batch mixing



Key features

Mixing time

The special design of the Vitomix results in a substantial improvement in mixing efficiency and a much more efficient and faster mixing process even at lower speeds. The Vitomix is up to 8 times faster than conventional mixers.

Adding liquids without creating lumps

The design of the two conical screws creates a fluidised bed in the upper part of the mixer cone that is perfect for adding liquids such as fats, coating agents, flavours and fragrances, without creating lumps. This eliminates the need for lump breakers.

Multi-processor

The Vitomix can combine its low and mid shear mixing with multiple unit operations, for example drying, heating, cooling, liquid addition, de-aeration and coating, in one machine.

Full discharge

The combination of a conical vessel, the special design of the mixing screw, and the large bottom outlet guarantees fast and full discharge, without the risk of segregation. Typical yield for free-flowing powders is 99.99%.



Short cycle times
State-of-the-art technology
Fast & gentle Multi-processor
Energy efficient
Full discharge

Models & specifications

The Vitomix is available in several sizes, ranging from 200 up to 10 000 litres. A few sizes with their basic characteristics are described below. Detailed information is available on request.

| Size | [l] | 500 | 1000 | 2000 | 3000 | 5000 | 7000 | 10 000 |
|---------------------|------|-----------|----------|----------|----------|---------|---------|----------|
| Vessel diameter | [mm] | 1230 | 1530 | 1900 | 2160 | 2550 | 2850 | 3200 |
| Vessel height | [mm] | 1260 | 1690 | 1890 | 2430 | 2870 | 2990 | 3350 |
| Height incl. motor | [mm] | 1590 | 2270 | 2480 | 3380 | 3860 | 3990 | 4570 |
| Typical motor power | [kW] | 1.1 - 5.5 | 3 - 18.5 | 5.5 - 30 | 7.5 - 45 | 15 - 75 | 22 - 90 | 30 - 110 |

High shear impact mixer

The Cyclomix is a revolutionary high speed paddle mixer designed for intensive mixing of cohesive powders. The mixing principle is based on a combination of high shear and high impact forces which can be used for different applications. The Cyclomix combines different processes in one single machine.

Typical applications

The Cyclomix is suitable for a wide variety of process applications, including:

- Intensive mixing of cohesive powders, slurries and liquids
- Coating of powders with powders or liquids
- Agglomeration by temperature or moisture addition
- Dispersion of pigments
- (Vacuum) drying at low temperature with liquid recovery
- Spheronisation of particles
- Grinding or de-agglomeration
- Heating or cooling

Working principle

The mixing vessel is conical shaped and has a central rotor which rotates at a tip speed of 3 up to 30 m/s. The speed of the rotor creates centrifugal forces that push the product to the vessel wall where the shape of the vessel causes an upward movement.

The domed cover guides the product towards the centre of the mixer and at the top, an impact blade efficiently disperses cohesive powders and liquids and controls particle size. The patented mixing mechanism of the Cyclomix ensures a homogeneous end product and an ultra-short batch time.



Batch mixing



Key features

Combined high shear and impact mixing

The unique combination of high shear and impact forces are used for mixing cohesive and/or sticky products.

Excellent temperature control

The design of the Cyclomix ensures accurate control of the product temperature. It offers an intensive mixing process with effective heat transfer between the heat-controlled jacketed wall and the product, enabling effective cooling and heating.

Seals above product zone

The rotor in the Cyclomix is driven from the top, and therefore has no seals or bearings that come in direct contact with the product.

Easy discharge

The Cyclomix has a conical shaped vessel with a central outlet at the bottom that guarantees easy discharge and optimal yield.



Multi-processor High shear High impact Temperature control Mixing & Agglomeration



Models & specifications

The Cyclomix is available in a wide range of sizes, ranging from 0.1 up to 2000 litres. A few sizes with their basic characteristics are described below. Detailed information is available on request.

| Size | [l] | 5 | 15 | 50 | 150 | 500 | 1000 | 2000 |
|-------------------------|------|------------|----------|--------|---------|----------|----------|----------|
| Vessel diameter | [mm] | 300 | 530 | 650 | 950 | 1400 | 1840 | 2250 |
| Outlet diameter | [mm] | 80 | 100 | 150 | 200 | 300 | 350 | 400 |
| Height incl. drive-unit | [mm] | 280 | 670 | 713 | 823 | 1178 | 2657 | 3125 |
| Typical motor power | [kW] | 0.75 - 5.5 | 1.5 - 15 | 4 - 30 | 11 - 75 | 30 - 110 | 45 - 160 | 65 - 240 |

High impact mixer

The Schugi Flexomix is a unique vertical continuous mixer and agglomerator, developed to achieve a highly homogeneous mixture of powders and liquids. It is unlike any other continuous mixer with its vertical cylindrical chamber and vertical rotating shaft. Its high rotational speed and turbulent mixing keep the mixer chamber clean; it provides accurate dosing of both liquid and solid components and is suitable for even the stickiest of media.

The Flexomix mixes powders with powders or powders with liquids excellently and homogeneously, even if the products are sticky. This also makes it highly suitable for wet agglomeration.

Typical applications

The Flexomix is suitable for a wide variety of process applications, including:

- Modification of starch
- Agglomeration of veterinary antibiotics
- Hydration of phosphates
- Agglomeration of detergents
- Finishing of filter cake
- Instantising of drinking chocolate
- Adding crosslinking agents to super absorbent polymers (SAP)
- Humidifying various products before extrusion
- Agglomerating pesticide formulae

Working principle

The Schugi Flexomix uses highly controlled mixing conditions to achieve optimal product characteristics and maximum efficiency. It is unlike any existing equipment and consists of a vertical cylindrical chamber enclosing a vertical rotating shaft. Several pitch adjustable knives are secured to the shaft, which rotate at high speed resulting in highly turbulent air flow.

Any number of powders can be fed into the unit through top inlet(s) whereby agitation causes a spiral flow and high collision rates in the suspension. Liquids of varying viscosity and steam can be added using atomizing nozzles mounted to the upper part of the chamber just above the upper mixing blades.

Power requirements are low as there is only ever a small amount of product in the mixing chamber at any one time, and the unit can be fully disassembled for major cleaning or product changes in just 2 minutes.

Continuous mixing

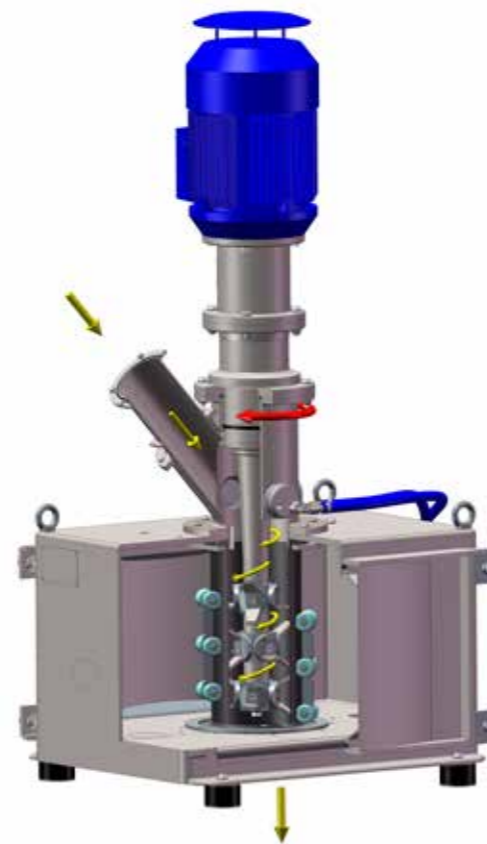

Key features

Gentle processing

The Flexomix requires minimal operator intervention and can process dry powders in combination with liquids into uniform and free-flowing, non-compacted, granular products using atomising nozzles. The gentle processing of the Flexomix produces dust-free instant products which dissolve quickly.

Simple construction

The Schugi Flexomix has a central rotating shaft with adjustable blades that is located in a vertical, flexible chamber. This has significant advantages when it comes to maintenance and cleaning. It has variable shaft speeds from 1000 to 3500 rpm and a set of pneumatically operated, external rollers that flex the mixing chamber continuously, maintaining the mixing conditions and keeping it clear of build-up.

Total solution

Hosokawa Micron B.V. designs and manufactures complete systems. In the case of the Schugi Flexomix for example, they can include final fluid bed dryers for use in the production of agglomerates. For other combinations, we can recommend taking advantage of our testing and tolling facilities and our wealth of operational data from existing Flexomix systems all over the world.



Mixing & Agglomerating
High shear High capacity
Multi-purpose Flexible
Efficient Accurate

Models & specifications

The Flexomix is available in 6 models. Their basic characteristics are described below. Detailed information is available on request.

| Model | [-] | FXD-100 | FXD-160 | FXD-220 | FXD-250 | FXD-335 | FXD-400 |
|-------------------------------------|--------|-----------|------------|------------|-------------|---------------|---------------|
| Dimensions (L x W) | [mm] | 540 x 520 | 702 x 620 | 976 x 880 | 976 x 880 | 1270 x 1100 | 1270 x 1100 |
| Height incl. motor | [mm] | 1261 | 1468 | 1967 | 1967 | 2770 | 2910 |
| Capacity (bulk density of 0.5 kg/l) | [kg/h] | 50 - 150 | 250 - 1000 | 800 - 2500 | 1000 - 3500 | 3000 - 10 000 | 8000 - 40 000 |
| Typical motor power | [kW] | 3 | 7.5 | 7.5 - 10 | 11 - 15 | 22 - 45 | 37 - 75 |

Modular mixer

The Modulomix is a continuous modular mixer based on proven Cyclomix batch mixing technology. It has been designed specifically for the pharmaceutical industry and can be used for low, medium or high shear applications. The Modulomix can be integrated in a PAT (Process Analytical Technology) environment.

For decades, pharmaceutical powder ingredients have been mixed using batch processes. However, continuous mixing is a very promising cost-saving device that can be recommended to pharmaceutical companies looking to reduce the costs of processing.

Converting to continuous processing also introduces a lot of new considerations which Hosokawa Micron B.V. can help you deal with. These considerations include:

- Feasibility trials
- Trials on a complete dry granulation production line
- PAT
- Defining batches in continuous processing
- Combining new processing equipment in existing production lines
- Up-scaling
- Reducing impact of start-up, change over and emergency downtime
- Minimising and dealing with off-spec product

Working principle

The Modulomix has been designed to be compact with fast reactivity, minimum residue and rapid start-up and shutdown protocols. It produces homogeneous blending in the blending chamber with little change to PSD (Particle Size Distribution) or temperature. Its intensive agitation regime produces a perfect mixture with extremely short residence times. It is fast and can be adapted to suit varying mixing conditions due to its variable speed as well as the design of its agitator blades. Mixing Mg-stearate for example, demands a different mixing regime to mixing drugs, which e.g. can be solved by cascading more than one Modulomix mixers in series.

As you can see in the flow diagram, up to 3 different products can be fed into inlet 1 at a time, thanks to the special inlet device on Modulomix 1. If required, you can also dose additional product(s) via inlet 2 on Modulomix 1, and all of these ingredients will be mixed efficiently by the Modulomix 1, normally under high shear conditions.

The lubricant can then be added through inlet 3 on Modulomix 1, which is directly connected to inlet 1 on Modulomix 2. The Modulomix 2 normally has lower shear conditions (needed for the lubricant) for creating the perfect final mix.

The final mix leaves the mixing system via a specially-designed PAT chute. Different PAT devices can be inserted to enable continuous control of the quality of the mix.

Continuous mixing

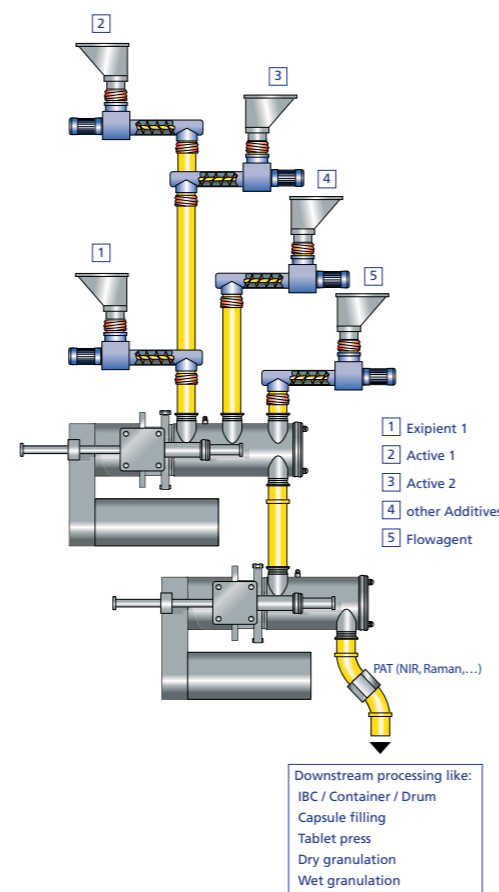

Key features

Short residence times

Thanks to the high shear agitation regime in the mixer, the average residence times are very short. Nevertheless, repeated trials have demonstrated almost no PSD shifts due to this agitation regime and very good RSD (Relative Standard Deviation) values. Even at low throughputs (< 1 kg/h), choosing the right feeder will give RSD (5 sec.) values well below 5%. These values can be reduced even further by the mixer(s).

Complete mixing system

The Modulomix has been designed to offer flexibility and adaptability as part of any continuous blending system. With help from our expert engineers, you will have no trouble specifying the best possible solution for all your powder processing requirements.

The Modulomix is a very compact blender that can be incorporated into Hosokawa Micron B.V.'s total continuous blending systems. This means that you can combine the Modulomix with Powder Transfer Systems (PTS), Loss-in-Weight (LIW) feeders, continuous blenders, PAT technologies and even downstream processing, like (wet) granulation and / or compacting.

A continuous Modulomix system could be complemented with:

- Refill system for pharma-feeders
- Reliable and accurate pharma-feeders (set point deviation $\leq 3\%$)
- Specially-designed filling system for dosing multiple feeder inputs into the mixing system
- Specially-designed PAT chute and PAT monitoring device(s)
- Specially-designed on-spec/off-spec downstream switches
- Specially-designed downstream off-spec bins
- Complete and PAT integrated controls (GAMP5)
- Easy connection to any downstream processing (granulation, tablet press, compactor etc.)



Continuous pharma mixer

Low to high shear
 Adaptable Compact Flexible
 Short residence times
 Minimum residue Fast reactivity

High speed paddle mixer

The Bepex Turbulizer is a continuous high speed horizontal paddle mixer with paddles located in a single helical or double helical pattern around the rotor shaft. It has maximum tip speeds of up to 50 m/s and is very effective at dispersing materials in a short amount of time. This high speed paddle mixer has been developed for fine and cohesive powder applications.

Typical applications

The Bepex Turbulizer is suitable for a wide variety of process applications, including:

- Dry powder mixing
- Hydrating difficult to wet powders
- Slurry mixing
- Coating
- Sterilisation
- Crystallisation
- Agglomeration / granulation
- Homogenisation
- De-lumping and finishing

Working principle

The Bepex Turbulizer consists of a horizontal rotating shaft with protruding and adjustable paddles, enclosed in a horizontal cylindrical chamber. It is self-cleaning; leaving no material traces behind in the machine, and operates at low volumes.

Typical residence times range from 2 to 30 seconds, making it ideal for low quantities. In combination with short residence times, this provides beneficial increases in energy efficiency.

The mixing intensity of this high speed paddle mixer can be tailored to the specific application by adjusting paddle pitch and shaft speed.

It is a compact mixer that is capable of extremely high heat transfer efficiency due to close contact between the material and the heated inside surface. It is highly suited to coating applications. In many cases, difficult to wet proteins can be instantised with the addition of less than 1% lecithin surfactant. In a similar process calcium carbonate materials can be insulated or effectively rendered insoluble with a coating of less than 1% stearate powder.

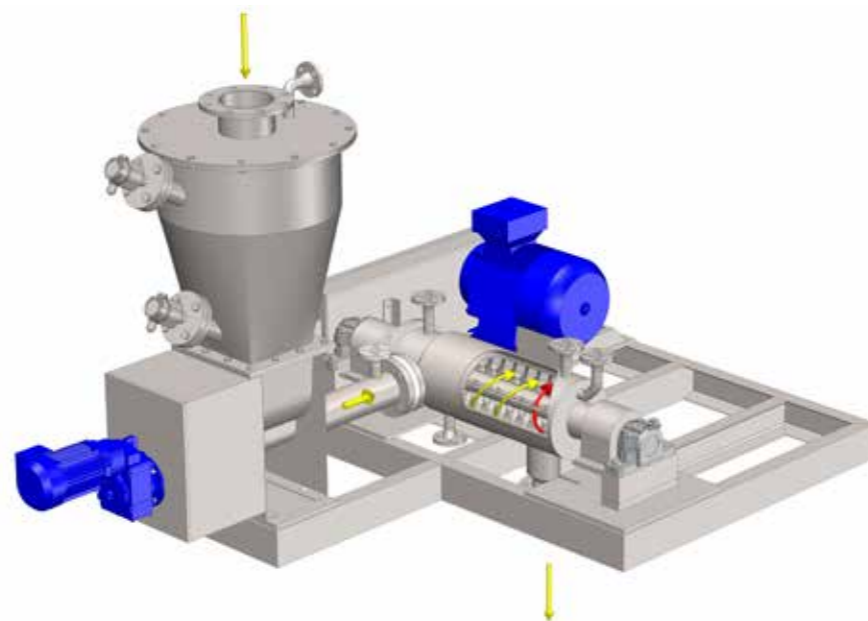

Continuous mixing



Key features

Versatile

The Bepex Turbulizer high speed paddle mixer offers flexibility and adaptability for a wide range of applications, like high-intensity mixing, coating, fine agglomeration or continuous reaction of powders with gases. All models are available with optional jackets for heating and cooling, with various materials of construction from mild steel or stainless steel to special metals.

Compact design

The Bepex Turbulizer is a compact paddle mixer that requires minimal floor space and head room.

Excellent cleanability

The thin layer of material in the mixer promotes excellent indirect heat transfer efficiency in jacketed models and a self-cleaning effect that eliminates lost product on start-up and shut down. Sanitary construction, compliant with international standards like EHEDG, can easily be achieved with the addition of gas-purged split-body seals and outboard bearings.



High speed High capacity
Versatile Flexible
 Compact design **Efficient**

Models & specifications

The Bepex Turbulizer is available in 5 models. Their basic characteristics are described below. Detailed information is available on request.

| Model | [-] | T-8 | T-14 | T-20 | T-30 | T-48 |
|---------------------|---------------------|----------|----------|---------|----------|-----------|
| Diameter | [cm] | 20 | 36 | 51 | 76 | 122 |
| Capacity range | [m ³ /h] | 1.3 - 3 | 5 - 17 | 12 - 42 | 32 - 110 | 100 - 340 |
| Tip velocity | [m/s] | 3.2 - 45 | 3.7 - 50 | 4 - 56 | 4 - 62 | 5 - 70 |
| Typical motor power | [kW] | 15 | 37 | 75 | 110 | 200 |

Lab equipment

Hosokawa Micron B.V. has an innovative range of equipment designed specifically for laboratory and pilot plants. Our equipment offers maximum flexibility and optimum solutions for product development and process optimisation. The equipment has been designed for small scale laboratory use and transfer to full scale production.

Standard Hosokawa lab equipment are plug and play units. The controls are scalable and provided with a frequency converter for variable speeds.



Modulomix

The Modulomix is a continuous modular mixer with a typical capacity of 2.5 to 10 kg/h. It is specifically designed for the pharmaceutical industry and can be used for low, medium or high shear applications.



Mini Cyclomix

High shear batch mixer based on the principles of the Cyclomix. Available in the sizes 0.1, 1, 2 and 5 litres. The unit can be used with a filling range of 30 - 100%.



Mini Flexomix

This high impact continuous mixer-agglomerator for lab environments has a typical capacity of 25 to 200 kg/h and is available as a single unit or as part of a total system including, for example, liquid and powder dosing and controls.



Mini Conical paddle mixer

Low and mid shear batch mixer available for lab environments in sizes up to 5 litres. The unit can be used with a filling range of 30 - 100%.



Minimix Vrieco-Nauta

The famous Vrieco-Nauta conical mixer is also available for use in laboratories or pilot plants as the Vrieco-Nauta Minimix. This series is available in sizes of 3.3 to 120 litres and offers the following advantages: high mixing accuracy, gentle mixing, complete discharge and flexible filling. The unit can be used with a filling range of 15 - 100%.

High shear

Mid shear

Low shear

Lab equipment/ Ancillaries

| Option | Vrieco-Nauta | Conical paddle mixer | Vitomix | Cyclomix | Flexomix | Modulomix | Bepex Turbulizer |
|-----------------------------------|--------------|----------------------|---------|----------|----------|-----------|------------------|
| Machine options | | | | | | | |
| Sampler | • | • | • | • | | | |
| Level indicator | • | • | • | • | | | |
| Liquid injection | • | • | • | • | • | • | • |
| Lump breaker | • | • | • | | | | |
| Knockers (pneumatic / mechanic) | • | • | • | • | • | • | • |
| Access door | • | • | • | • | • | | |
| Split body | | | | | | | • |
| Heating / cooling jacket | • | • | • | • | | • | • |
| Load cells | • | • | • | • | | | |
| ISEM ball segment valve | • | • | • | • | | | |
| Slide gate valve | • | • | • | • | | | |
| Charging hopper | • | • | • | • | | | |
| Orbit arm positioning | • | | • | | | | |
| Hinged cover | • | • | • | | | | |
| Filter | • | • | • | • | | | |
| Lifting device / Steel structure | • | • | • | • | • | • | • |
| Temperature sensor | • | • | • | • | • | • | • |
| Pressure sensor | • | • | • | • | | | |
| Intensifier | • | | | | | | |
| CIP/WIP | • | • | • | • | • | • | • |
| Powder and / or liquid dosing | • | • | • | • | • | • | • |
| (System) controls | • | • | • | • | • | • | • |
| Design options | | | | | | | |
| Hygienic design | • | • | • | • | • | • | • |
| Vacuum / pressure design | • | • | • | • | | | |
| Sterile / aseptic design | • | • | • | • | | • | |
| Wear / corrosion resistant design | • | • | • | • | • | • | • |

Ancillaries / options

Charging hopper

Mixers can be delivered with a charging hopper for manual charging which can be installed on the mixer cover and is available in two sizes: for single and dual person operation. The standard model has been designed with a hinged access door, bolted grid and dust exhaust connection. 'Vibrating' grid and/or CIP nozzles are optional.



Access door

An access door can be integrated into the vessel wall for easy access during inspection and cleaning. It offers a safe and ergonomic access to the interior of the mixer and its design guarantees an optimal dust- and watertight closure using FDA approved sealing.



Sampler

The Hosokawa sampler allows for powder sampling in reactors, mixers, tanks, dryers or similar vessels without interrupting operation. Sampling can be carried out in a normal atmosphere, under pressure or vacuum, without affecting its functionality. The sampler fits into the process vessel without creating any dead spots and guarantees reliable sampling.



ISEM ball segment valve

The ISEM ball segment valve is a multi-purpose valve originally designed by Hosokawa. The full bore passage offers a free product discharge, without valve parts disturbing the flow of the product. It can be used for liquids, gases, pastes and powders, including abrasive and aggressive applications. Depending on the requirements it can be delivered for use in processes under normal atmosphere, pressure or under vacuum.



System Solutions

From concept to commissioning

We have a wide range of high-quality individual technologies for you to choose from, but what we pride ourselves on the most, is our ability to help and support our customers from concept to commissioning and beyond. We enjoy working in close collaboration with our customers, and would happily help you find the optimum solution for your specific process requirements.

We have included a number of examples of systems solutions on the following pages that illustrate the kinds of systems we can provide. For more information on developing a bespoke processing solution, please contact our technical advisors.

System integration

System integration is key when trying to achieve quality and efficiency in mixing. It is a delicate balance between conveying, charging, mixing, discharging, sieving, packing and so on, which is why we offer tailor-made mixing systems, designed and manufactured to your exact specifications.

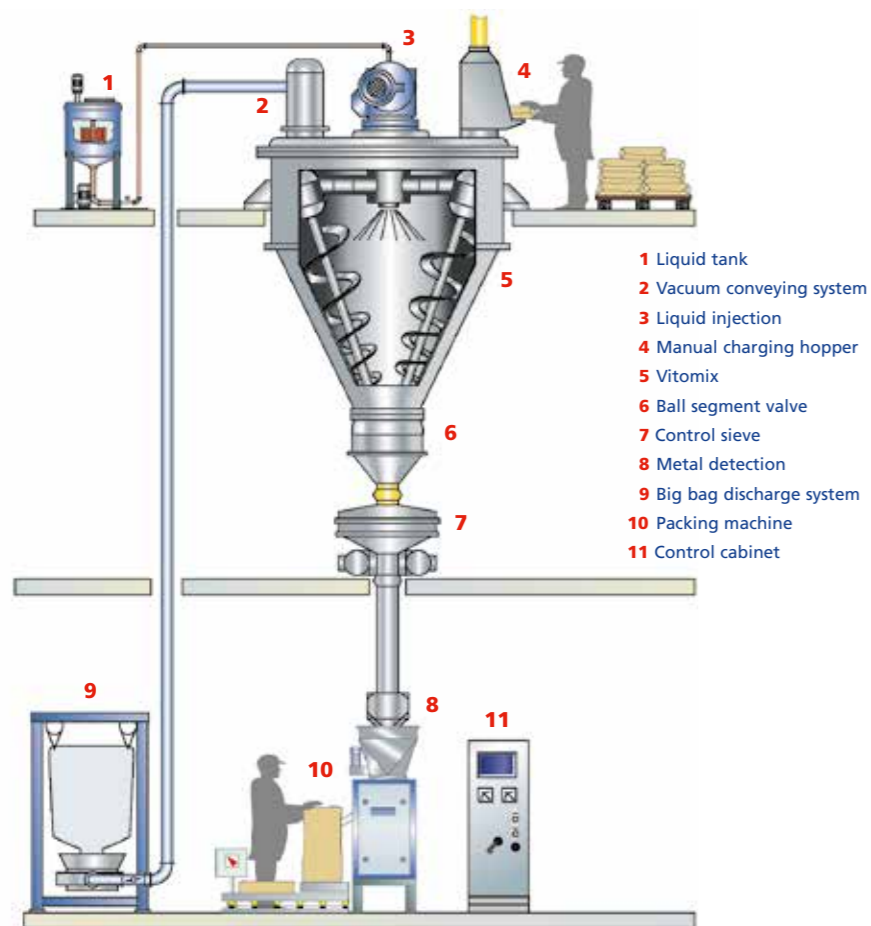

Vitomix food system

System Solutions

Preventing dust explosions

Hosokawa Micron B.V. has realised numerous projects under strict ATEX-conditions and has participated in many risk assessments. We have ATEX certification for the majority of the Vrieco-Nauta mixers and vacuum dryers, which guarantees safe operation in explosive environments.



If potential ignition source(s) are unavoidable, we can help you to implement countermeasures in the design according to ATEX-directives.

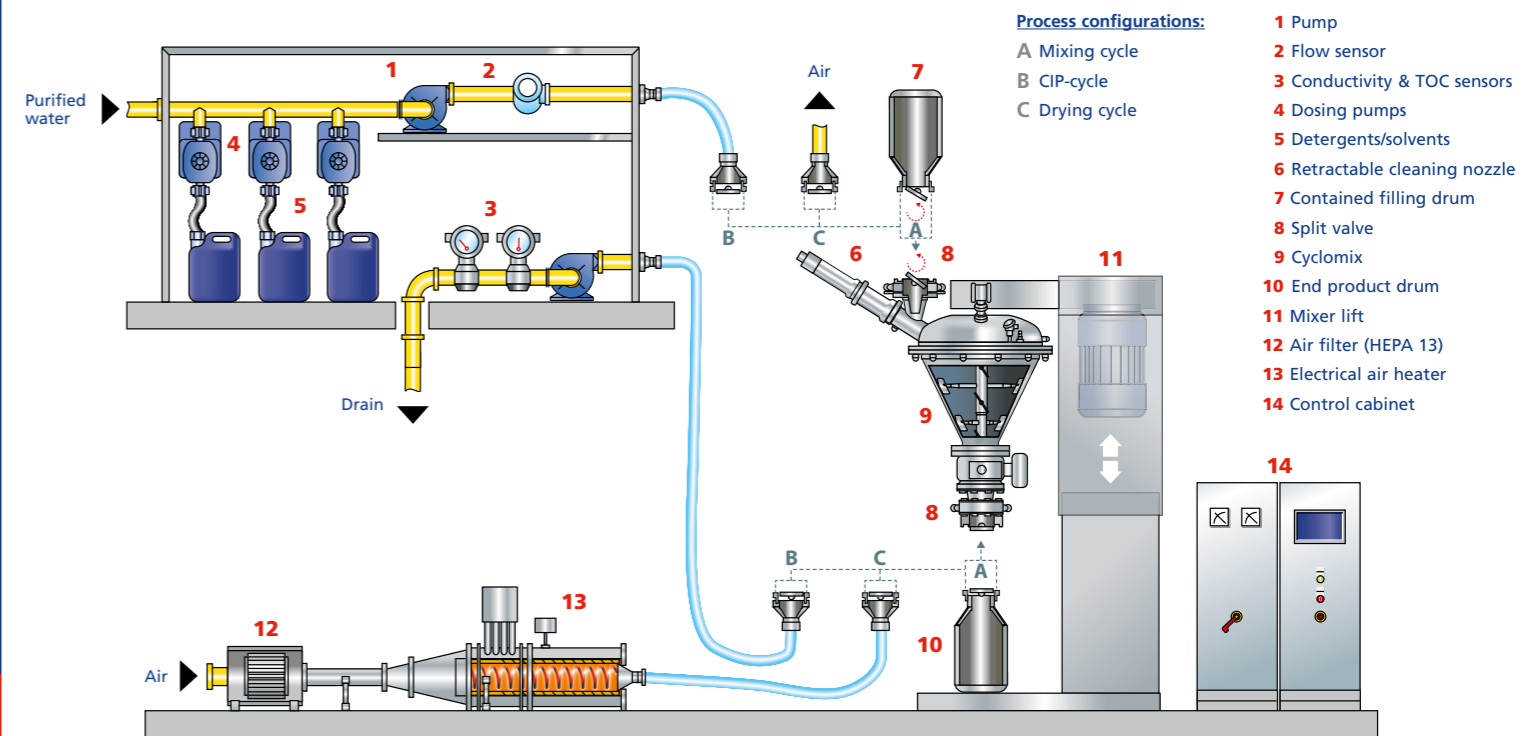

Cyclomix inhaler system

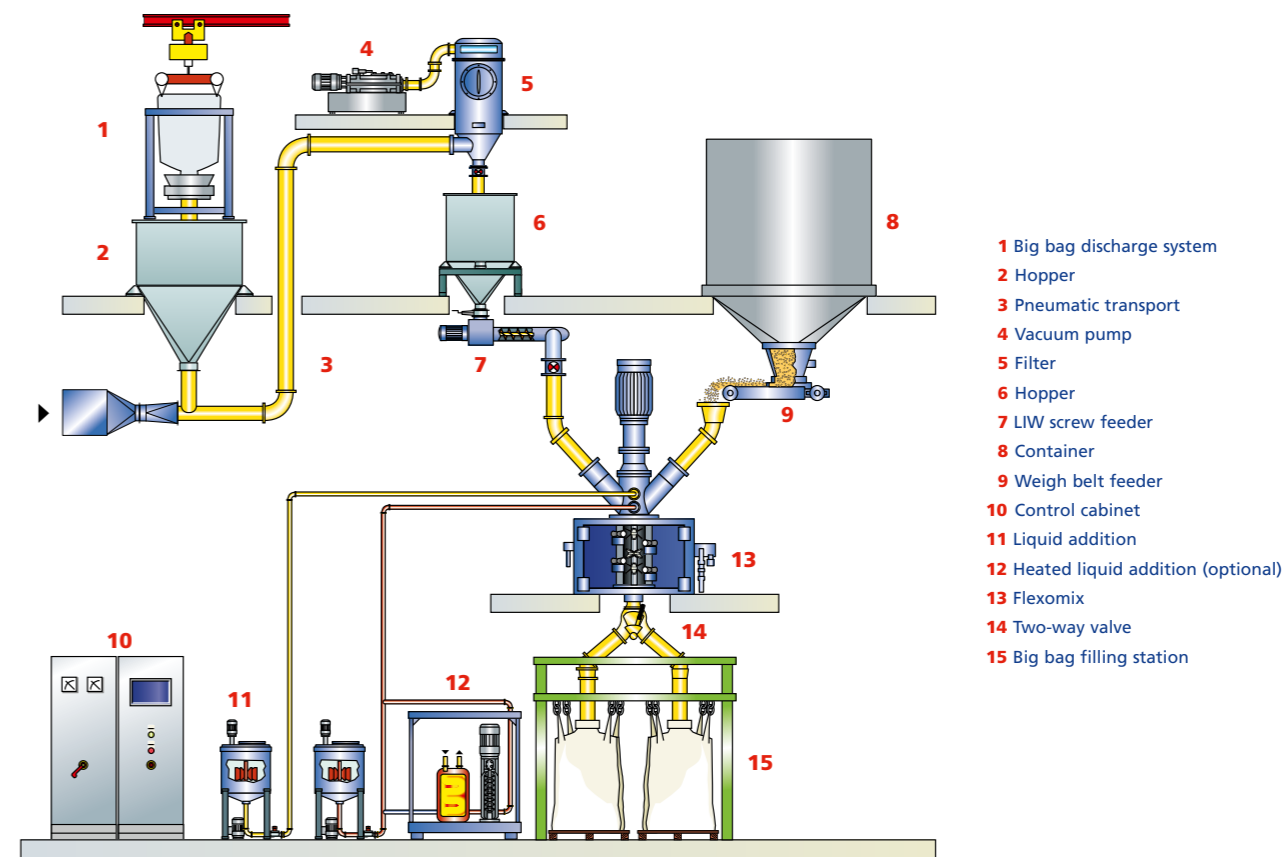

Flexomix pesticides system

Process Automation

Process automation is an inextricable part of every mixing system, which is why Hosokawa Micron B.V. has an experienced team of process and electrical engineers at hand to help you identify the right degree of automation for your processes. Our engineers are experts in translating process technology know-how into essential hardware and essential software for optimum custom-made control solutions.

Qualification

Prior to the planning stage, our engineers will investigate the special demands of your production sequence, the restrictions created by the supply network and the environmental conditions in your production area (e.g. a potentially explosive atmosphere, for example gas and/or dust). They will then systematically convert their findings into a viable concept.

The diagram below illustrates the process that our engineers adopt for system qualification.

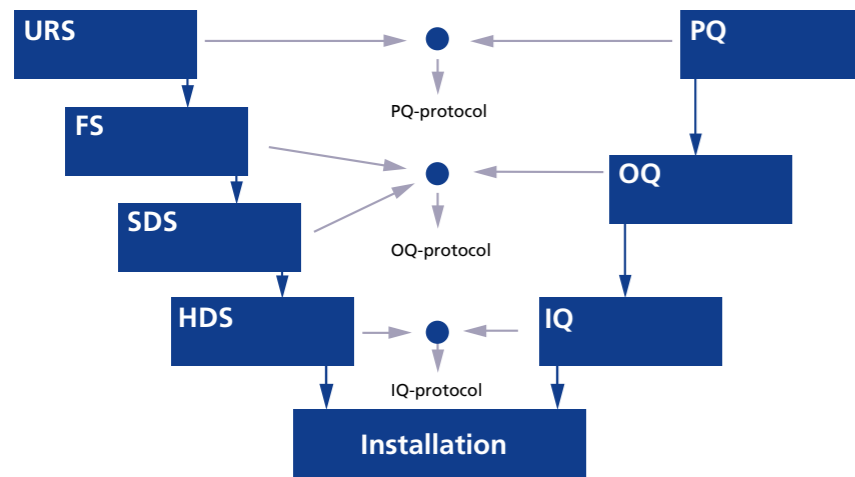

Hardware

Selecting the correct hardware is essential for an efficient and reliable production sequence. Our engineers combine safety, switching and operating elements that best suit the production process and the environmental conditions of your production site and incorporate these into your custom-made control cabinet. It is inspected and tested before leaving Hosokawa Micron's manufacturing facilities in terms of functionality and quality and in accordance to international IEC and EN standards.



Process Automation



Software

We then create a tailor-made software program that matches your process precisely, but is nevertheless flexible enough to allow for quick and easy adaptations or process upgrades. The process control software is universally structured and documented. We use tried and tested program modules for maximum reliability. These can be retrieved from libraries, permitting efficient program generation for your process control unit.

Before the process control unit is delivered, we carefully test the function of the software. This means that you can concentrate fully on process optimisation during the implementation, without having to worry about any unwanted delays.

Process visualisation

We have two different visualisation systems available depending on your requirements. For simple processes, we provide a Windows-based operating and monitoring system. For more complicated processes, we work with state-of-the-art process visualisation software.

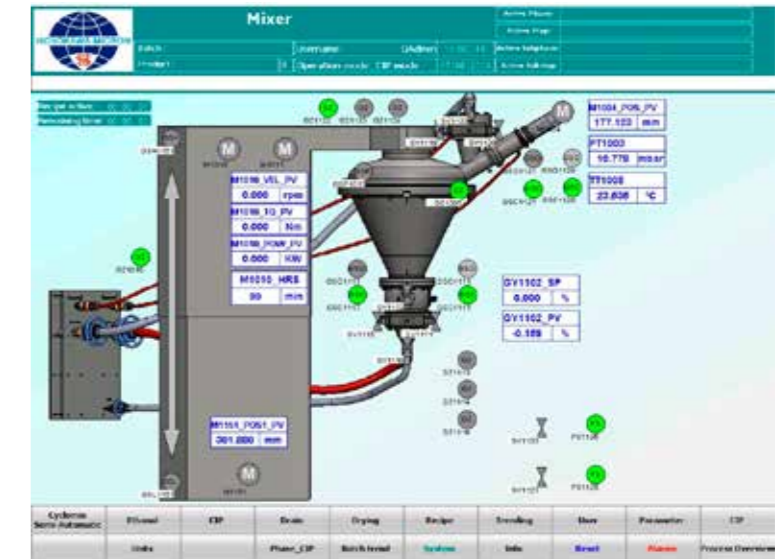

User-friendly & reliable

Hosokawa Micron's systems, hardware and software are all tried and tested. Our control solutions have been implemented throughout a wide variety of industries. They are user-friendly, error-free and reliable, because we have reinvested the practical experience gained from these implementations into the optimisation and improvement of our process technologies and our automation controls.

Practical operation
Modular **User friendly**
 Tailormade **Reliable**
Automation engineering
 Process visualisation



Service & Support

Downtime is unacceptable, which is why customers demand security and peace of mind for their processes and service and support for their machinery. Hosokawa Micron B.V. can pride itself on a highly-competent engineering department and a responsive and smoothly operating service department.

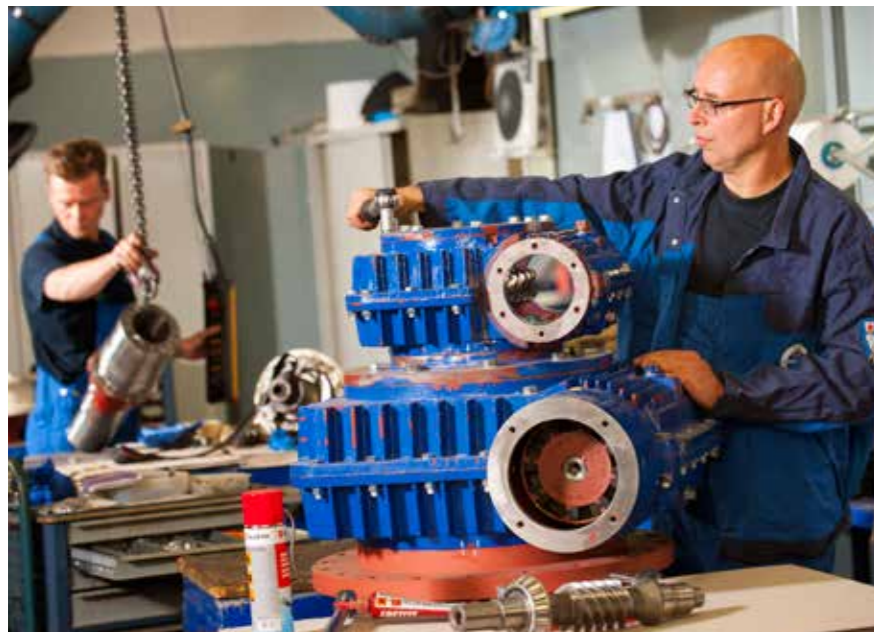

Repair & maintenance

Our Technical Services Team carries out repair and maintenance services onsite or in our own fully-equipped workshop in Doetinchem, The Netherlands. This team comprises specialists in mechanical engineering, maintenance, instrumentation and controls as well as process engineering.

Protect your investment

Create added security for your capital investment with one of our regular maintenance contracts. Our sales engineers will be more than happy to discuss a bespoke agreement that meets your specific maintenance needs, either for single machines or entire process lines.

Spare Parts Service

Minimise the hassle of sourcing spare parts with our Spare Parts Service. We have a team of engineers on standby that can deliver the spare parts and install them for you on site. And if that isn't efficient enough, we will happily discuss the options for your own in-house Hosokawa Micron B.V. inventory: spare parts to hand, 24/7.

Predictable **Reliable**
24 hrs service & support

Avoid down-time **Upgrade**
Repair Value for money
Improve Replace

Service & Support



+31 (0)314 37 35 05



Preventative maintenance

Preventative maintenance means knowing that your production processes are in good working order and increasing the lifetime of your plant. Hosokawa Micron B.V. has a dedicated team of experienced maintenance engineers specialised in just this: providing on-site advice, engineering and training to help you optimise your processes. Our experienced engineers are focussed on identifying potential mechanical, safety and process line problems before they cause unnecessary downtime.



Service Department Hosokawa Micron B.V.

On site services

- Preventative maintenance
- Inspection and troubleshooting
- Repair & service
- Process support and optimisation
- Modifications and upgrading to latest technology
- Internal transport, relocation and construction
- Operator training either onsite or in Doetinchem, The Netherlands
- Commissioning
- Certification and validation
- Reconditioning of used machines
- Swap drives

Replacing old machinery with new

A retrofit, upgrade or refurbishment can be easier and more economical than specifying and buying new. Hosokawa Micron B.V. offers exactly that: a combination of our high-quality products and spare parts with expert design and engineering as well as experienced manpower. Our goal is to make sure you are left with equipment that performs at the same level as the brand-new equivalent.

Retrofitting

We will send in our expert engineers for an initial assessment, fix mechanical failures and replace broken parts. In short, we will give your machines a new lease of life. Any new parts come with a 12-month guarantee but may well last much longer; 25-30 years is no exception! That's what we call value for money.

Upgrading

Our engineers can also help you improve production, increase capacity and upgrade your existing processes to the latest industry standards. We can minimise mechanical failures, convert to food-grade specifications and CIP cleaning, all without necessarily having to replace the entire system.

Refurbishment

Refurbishment is more than a retrofit or upgrade. It's the whole package. From start to finish, we will work with you to improve your processes: come up with a plan, improve, repair, replace and upgrade whilst considering the application, the market sector, industry standards and of course your wishes and requirements.





Testing & Tolling

Hosokawa Micron B.V. has its own testing and development centre in Doetinchem, the Netherlands. It offers unique possibilities for testing your product to determine the most efficient process, system or plant prior to final design. We can provide laboratory as well as production-sized trials.

Whether you wish to test a single machine or a complete powder processing system, the same skilled and experienced staff are here to help ensure that your requirements are met, and that you are entirely satisfied with the results.

We have test equipment at your disposal for:

- Batch mixing from 1 up to 6000 litres
- Continuous mixing from 2.5 up to 1000 kg/h
- Batch vacuum drying from 5 up to 6000 litres
- Batch freeze drying of 1.5, 5 and 60 litres
- Continuous drying from 1 up to 250 kg/h (evaporation)
- Batch agglomeration from 5 up to 500 litres
- Continuous agglomeration from 50 up to 500 kg/h

Is testing necessary?

If we could summarise the behaviour of powders in a set of rules and guidelines, in other words, if results could be predicted, then testing would be unnecessary. Of course the reality is somewhat different. Testing isn't only necessary; it is the foundation of any successful product or process. At Hosokawa Micron B.V., we enjoy helping our customers test their latest ideas and requirements and with our modern testing facilities, we can help you put theory into practice.

Testing & Tolling



Rental equipment

Our testing centre is full-equipped with all of our latest equipment for operational trials but we also offer a range of rental equipment so that you can carry out operational trials at your own facilities too. This means that you can fine tune process parameters and monitor production flows prior to finalising equipment choices and process designs. To help things go smoothly, our experienced process engineers will work closely with your engineering team to advise and develop the best solution for your processing requirements.

For more information and availability please contact us.



Toll processing & Contract manufacturing

Besides testing, we also offer a wide range of toll processing & contract manufacturing services ranging from single to multiple processes, for batch and continuous mixing, drying and agglomeration.

Your advantages:

- Clearly defined costs
- No investment in equipment and buildings
- Efficient production of small quantities
- Test your process on a lab and production scale
- Define the specifications of your machine
- Use toll processing as part of your development process
- Produce materials for marketing activities, prior to investing in new production capacity
- Fill the gap between design and start up of your new equipment or plant
- Launch new products using toll processing, until your sales have reached a solid and profitable base



Testing
 Contract manufacturing
Toll processing
Rental equipment
 Laboratory- and production scale trials

Food industry

The food processing industry works non-stop to develop new products that meet product safety & quality standards, as well as traceability and all this in a competitive market.

We offer a unique range of processing systems for the food industry including batch and continuous mixers for laboratories and pilot plants, through to full-scale production and complete systems solutions. Our focus is on continuing research & development of our products and services to support you in yours.

Food Safety & Hygienic Design

Hosokawa Micron B.V. is an active participant in the European Hygienic Engineering & Design Group (EHEDG). This is a consortium of equipment manufacturers, food industries, research institutes and public health authorities whose goal is to increase food safety by improving hygienic engineering and design in all aspects of food production. The long term benefit is not only improving product safety, but also increased durability of equipment, reduced maintenance and lower operational costs.

The food grade equipment Hosokawa Micron B.V. offers, is engineered and manufactured in accordance with EHEDG and 3-A standards.



Savoury products

- Milk powder**
- Confectionary**
- Flavours & fragrances**
- Tea**
- Sugar**
- Instant soup**
- Vitamins**
- Baby food**
- Gelatine**
- Herbs & spices**
- Starch**
- Coffee**
- Seeds**



Industries



Spice up your Operations



Applications and processes

- Mixing of infant milk powder
- Mixing, chemical and heat treatment of starch
- Mixing and sterilisation of herbs and spices
- Mixing, alkalisation and agglomeration of cocoa
- Mixing and flavouring of tea & coffee
- Homogenisation of gelatine, alginates, pectin
- Mixing and pasteurisation of egg powder
- Mixing, agglomeration and moisture manipulation of flour
- Mixing of vitamin flour and paste
- Mixing of sugar crystals and powder
- Mixing of pastes and sauces
- Coating and mixing of seeds
- Mixing of meat and fishmeal

Services

- Global development, sales and service organisation
- Process development
- Customer support by professional engineers
- Process testing, up-scaling and validation in well-equipped test centres
- Toll production for market development
- Customised design service in accordance with EHEDG, 3-A or customers guidelines



Bakery products



Spices & flavours



Cocoa



Infant formula

Pharmaceutical industry

Hosokawa Micron B.V. has a wealth of experience in pharmaceutical processing and is up to date with the latest developments in the pharmaceutical industry and the transition towards continuous processing. In anticipation of this changing trend, we have developed a continuous blender, the Modulomix.

We have also been working on innovations in our batch mixing technologies to continue improving performance and to fine tune our technologies to the latest industry requirements, like CIP/SIP.

High standards

Reducing and managing risks and safe guarding safety has the highest priority in the pharmaceutical industry. Complying with the industry standards like cGMP and GAMP is a pre-requisite. Our control systems can be supplied in accordance with the 21 CFR part 11 requirements.

The highest possible standards are crucial when it comes to hygiene, but issues like climate controlled logistics, safety and control systems are all elements we can discuss when helping you select the right mixer or fully-integrated mixing lines.

The low shear mixing of granules for oral applications for instance, has been carried out in the well-known Vrieco-Nauta mixers for a long time. For high shear mixing of dry powder Inhalers, you should choose the Cyclomix.

Upscaling

Our equipment is available in sizes suitable for R&D, clinical trials as well as for manufacturing; and we will happily support you with process up-scaling if required.

- Laboratory scale batches: 0.1 - 5 litres
- Development scale batches: 1 - 120 litres
- Manufacturing scale batch size: 25 - 10 000 litres

Uniform dosage forms
 Veterinary products **API**
 Cell culture media
Respiratory drugs (DPI)
Nanopharmaceuticals
 Parenterals Tooth paste
Sterile intravenous drugs
 Excipients such as lactose, sugar, cellulose

Industries



Special care for your products

Applications and processes

- Batch mixing of active ingredients and excipients and/or lubricants for oral applications
- Formulation of active ingredients and excipients for Dry Powder Inhalers
- Continuous mixing of active ingredients and excipients.
- Coating of fine bulk carrier with liquids and/or nano active ingredients
- Mixing of excipients like lactose with lubricants before tablet press
- Mixing / dispersion systems for cosmetic facial powders
- Mixing of wet and dry granulated material with lubricant
- Heat treatment or cooling of powders
- Addition of moisture
- Mixing of nutraceutical products like vitamins
- Sterilisable systems

Services

- Global organisation and support
- Process development support and testing facilities
- Rental equipment available for testing purposes
- Scale up support from lab to industrial production
- Our systems comply with the latest international standards
- Customised system design
- CIP/SIP functionality
- Validation documentation



Phase 1
Drug discovery & development



Phase 2
Lab testing



Phase 3
Equipment development



Phase 4
Production of equipment

Chemical industry

The field of activity of the chemicals division is just as wide and diverse as the overwhelming number of substances for which Hosokawa Micron B.V. offers mixing solutions. The mixing process in the chemical industry is often critical, demanding the highest of industry standards. Three important aspects worthy of special attention are flexibility, reliability and safety.

Flexibility

As product life cycles shorten, production facilities in the chemical industry need to be equipped for making easy adjustments for the manufacture of alternative products. Our mixers and system solutions are designed for this very purpose: for handling a wide range of different materials with varying product properties.

Safety

The chemical industry synonymous with hazardous materials, and mixing them is a specialist field. Needless to say, Hosokawa Micron B.V. is expert in this field, and works to stringent safety standards for all of its products and process systems.

Reliability

We offer state-of-the-art technology that has proven to be highly efficient and extremely reliable. Every system is engineered for high performance with maximal durability and minimal downtime. To ensure this, we always apply adequate measures for maximal safety, for your product, the operator and the environment.

Industries



Feel the chemistry



Applications and processes

- Batch mixing of pesticides
- Batch mixing of conventional and chemically produced toner (CPT)
- Continuous mixing (crosslinking) of super absorbent polymers (SAP)
- Continuous mixing and agglomeration of detergent powders
- Continuous mixing and agglomeration of soil improvers
- Mixing of recycled and virgin polymer
- Batch mixing / coating of flame retardant
- Homogenisation of battery mass
- Dispersion of pigments
- Coating of magnesium hydroxide
- Master batching of polymer and pigments

Services

- Global organisation and support
- Application and process development
- Process simulation to prove product quality and process functionality
- Up-scaling from pilot to industrial scale
- From single unit to turnkey system
- Dedicated project management
- A variety of contract production services
- Toll processing



Pigments



Catalysts



Agrochemicals



Super Absorbent Polymers (SAP)

Catalysts

Zeolite PE resin
Metal stearates

Acrylates PVC
Copper hydroxide

Dicalcium phosphate Pigments

Titanium dioxide

CMC Magnesium hydroxide



Minerals & Metals industry

Hosokawa Micron B.V. provides the minerals and metals industry with a wide range of reliable and robust mixing equipment. We offer proven technologies and have the know-how and experience for successful operational concepts for all kinds of product. We know how important high productivity, reliability and low operational costs are, and enjoy finding the optimum solutions for our customers.

Productivity

Batch processing in large volume mixers is often the most suitable solution for large quantity mixing. For these applications, we recommend mixers with low power requirements such as the Vrieco-Nauta conical mixer. The low power requirements result in improved energy efficiency, as well as reduced wear.

Another way of processing large batches, is by mixing smaller volumes with very short batch times. The Cyclomix is ideal for this. For continuous mixing, we can provide compact mixers that are extremely accurate at mixing large volumes. The Flexomix and the continuous paddle mixer are two good examples.

Wear protection

Energy consumption and replacement due to wear are two of the biggest operational costs in the minerals and metals industry. To combat this, the Vrieco-Nauta conical mixer has been designed to consume very little energy, which in turn reduces the amount of abrasion inside the mixer. For highly abrasive applications, parts can also be protected against wear, which can optimise life cycle costs even further.

We recommend wear protection if you deal with high-intensity batch and/or high-speed continuous mixing.

Gypsum **Ceramics**
 Calcium carbonate
Feldspar **Talc** **Zeolite**
 Bentonite
Kaolin **Zircon sand**
Graphite **Metal powders**
 Rare earths elements

Industries



Rock solid solutions

Applications and processes

- Batch mixing of metal powders with bulk density up to 3.5 kg/l
- Batch mixing of cement slurry and pigments
- Mixing of metal or oxide powders and pastes for products like iron, aluminium and bronze
- High accuracy mixing of minerals and metals with additives, pigments or flow agents before sintering, calcinations or compaction
- Coating of calcium carbonate
- Coating of magnesium carbonate

Services

- Global organisation and support
- Process development
- Process simulation for product quality and process functionality
- Testing & Tolling
- Contract production
- Single units to turnkey systems



Cement



Metal powders



Ceramics



Welding powders

HOSOKAWA MICRON GROUP WORLDWIDE

Hosokawa is the world's largest provider of processing systems for the field of powder and particle processing. Renowned names such as Alpine, Micron, Mikro, Stott, Vitalair and Vrieco-Nauta® are all included in the Group's range. Regardless of the size, i.e. production-scale systems, pilot systems or laboratory equipment, Hosokawa's products and technologies are used in numerous process stages, for example during mixing, drying, agglomeration, containment, filling, metering, size reduction and classification.

CONTACT

Hosokawa Micron Polymer Systems,
Berlin, CT (USA)

Hosokawa Micron Powder Systems,
Summit, NJ (USA)

Hosokawa Micron Powder Systems
S.A. de C.V. Mexico City (Mexico)

Hosokawa Micron Ltd.
Runcorn (UK)

Hosokawa Micron St. Petersburg OOO (Russia)

Hosokawa Micron B.V. Doetinchem (The Netherlands)

Hosokawa Alpine Compaction, Leingarten (Germany)

Hosokawa Alpine AG, Augsburg (Germany)

Hosokawa Micron SA,
Évry (France)

HOSOKAWA MICRON CORPORATION (Japan)
Headquarters
No. 9, 1-Chome, Shoudai-Tajika,
Hirakata, Osaka, 573-1132
Tel: +81 728 552 704

Hosokawa Micron Ltd.
Seoul (South Korea)

Hosokawa Micron Powder
Machinery Co. Ltd. Shanghai
(China)

Hosokawa Micron Pvt. Ltd.
Chennai (India)

Hosokawa Micron SDN BHD,
Kuala Lumpur (Malaysia)

- Hosokawa Sales Office
- Engineering / Manufacturing / Test Centre

THE NETHERLANDS
Hosokawa Micron B.V.
 Gildenstraat 26
 PO Box 98
 7000 AB Doetinchem, NL
 Phone: +31 314 373 333
 E-mail: info@hmbv.hosokawa.com
 Internet: www.hosokawamicron.nl

TEAM FOOD
 Phone: +31 314 373 463
 E-mail: food@hmbv.hosokawa.com

TEAM PHARMA
 Phone: +31 314 373 461
 E-mail: pharma@hmbv.hosokawa.com

TEAM CHEMICALS/MINERALS/METALS
 Phone: +31 314 373 460
 E-mail: cmm@hmbv.hosokawa.com

TEAM SERVICE
 Phone: +31 314 373 372
 +31 314 373 374
 E-mail: service@hmbv.hosokawa.com

After office hours
 Phone: +31 314 373 505





HOSOKAWA MICRON B.V.

Hosokawa Micron B.V. is a member of the Hosokawa Micron Group, responding to global needs through emphasis on materials science and engineering.

The Group is an international provider of equipment and technology for powder and particle processing, plastics processing and confectionery products.

The Group maintains facilities for research, engineering, manufacturing and service in each of the world's major industrial markets.

© 2016 Hosokawa Micron B.V. Doetinchem, The Netherlands